

LINSEIS

T H E R M A L A N A L Y S I S

DIFFERENTIAL SCANNING CALORIMETER

Chip-DSC 100

Chip-DSC 10

Chip-DSC 1

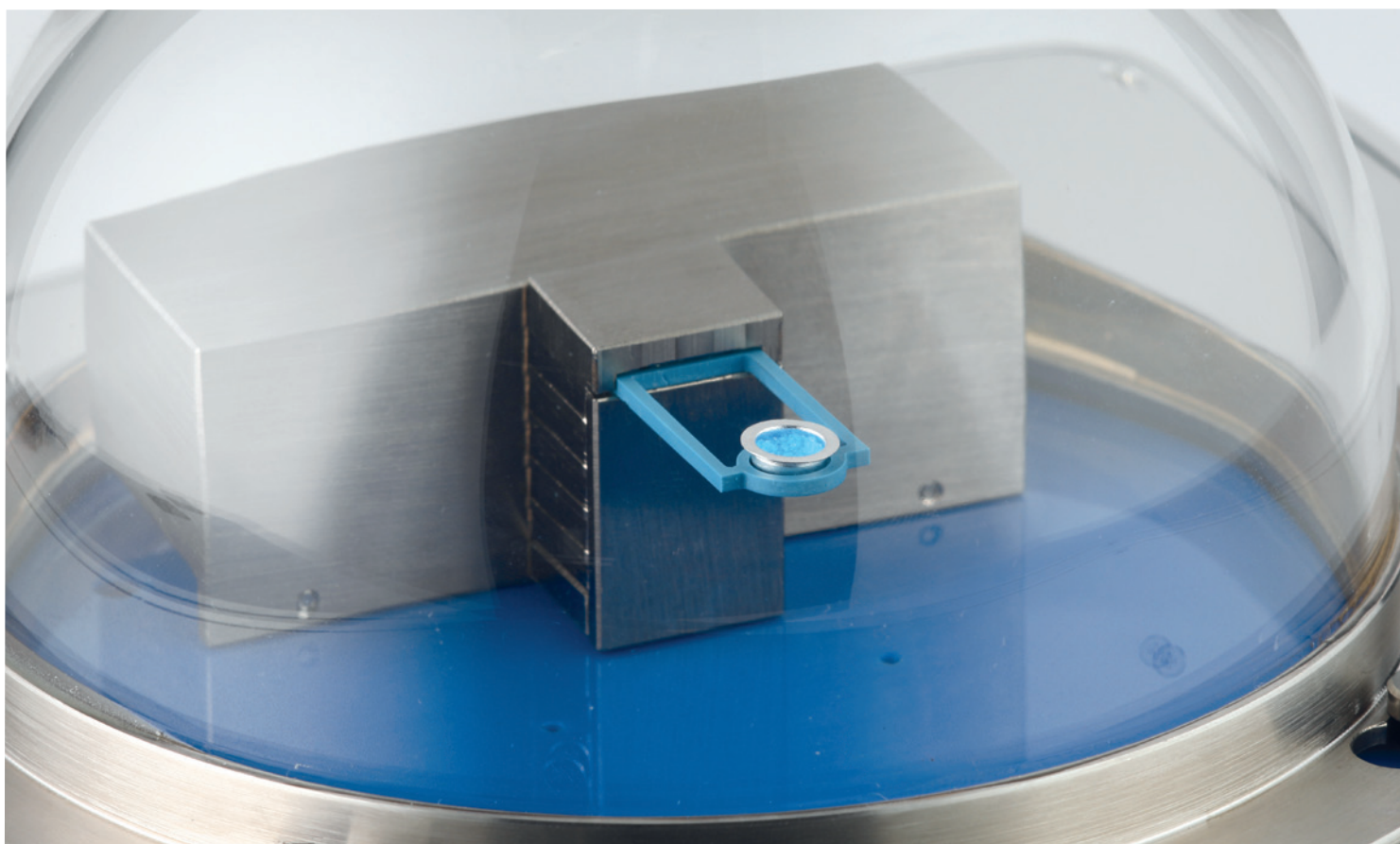

Since 1957 LINSEIS Corporation has been delivering outstanding service, know-how and leading innovative products in the field of thermal analysis and thermophysical properties.

Customer satisfaction, innovation, flexibility and high quality are what LINSEIS represents. Thanks to these fundamentals our company enjoys an exceptional reputation among the leading scientific and industrial organizations. LINSEIS has been offering highly innovative benchmark products for many years.

The LINSEIS business unit of thermal analysis is involved in the complete range of thermoanalytical equipment for R&D as well as quality control. We support applications in sectors such as polymers, chemical industry, inorganic building materials and environmental analytics. In addition, thermophysical properties of solids, liquids and melts can be analyzed.

LINSEIS provides technological leadership. We develop and manufacture thermoanalytic and thermophysical testing equipment to the highest standards and precision. Due to our innovative drive and precision, we are a leading manufacturer of thermal analysis equipment.

The development of thermoanalytical testing machines requires significant research and a high degree of precision. LINSEIS Corp. invests in this research to the benefit of our customers.



Claus Linseis
Managing Director

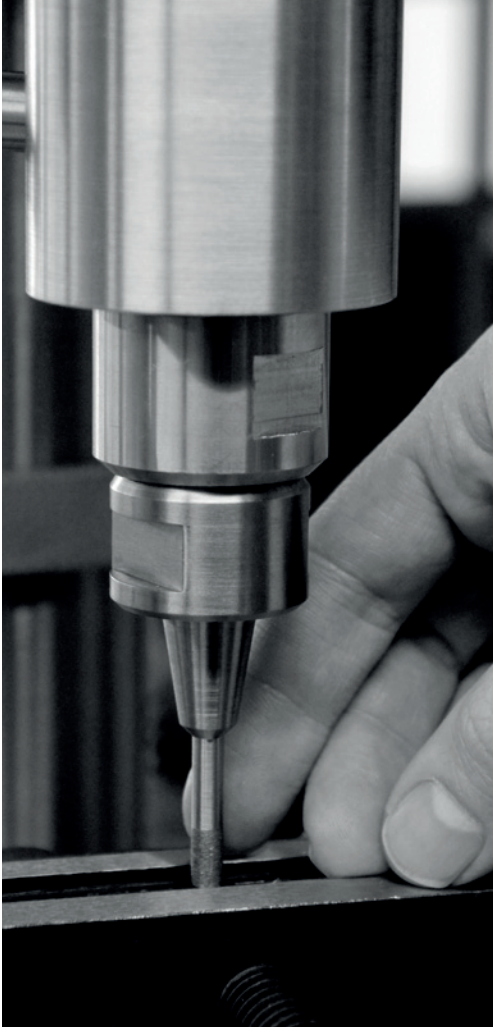

German engineering

The strive for the best due diligence and accountability is part of our DNA. Our history is affected by German engineering and strict quality control.

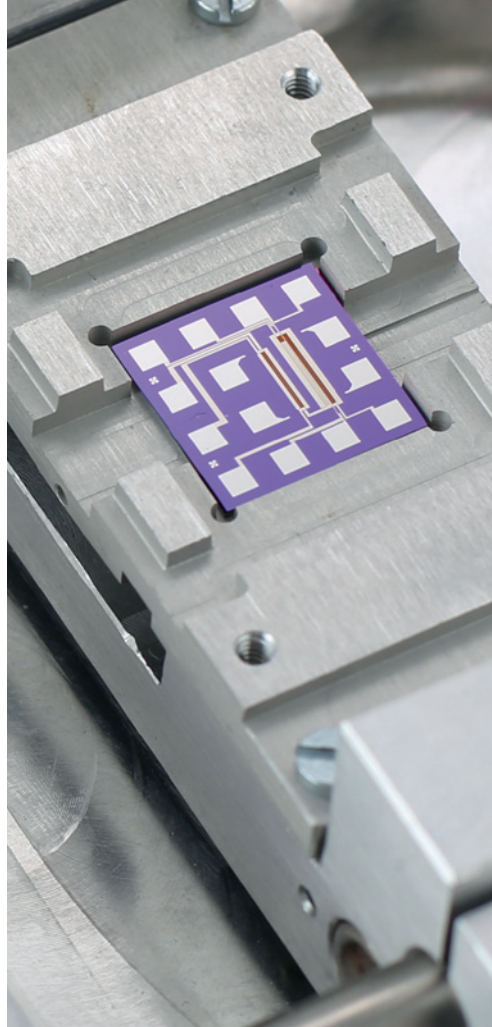

Innovation

We want to deliver the latest and best technology for our customers. LINSEIS continues to innovate and enhance our existing thermal analyzers. Our goal is constant development of new technologies to enable continuous discovery in science.

DIFFERENTIAL SCANNING CALORIMETER

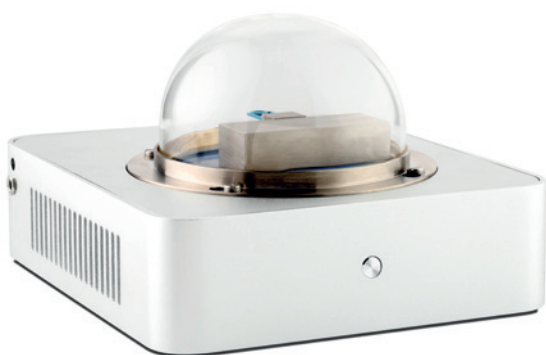

Chip-DSC 1

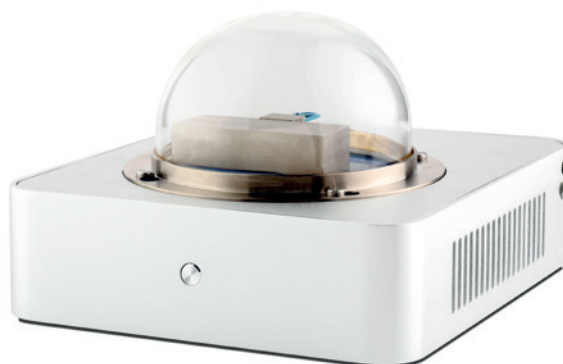

Chip-DSC 10

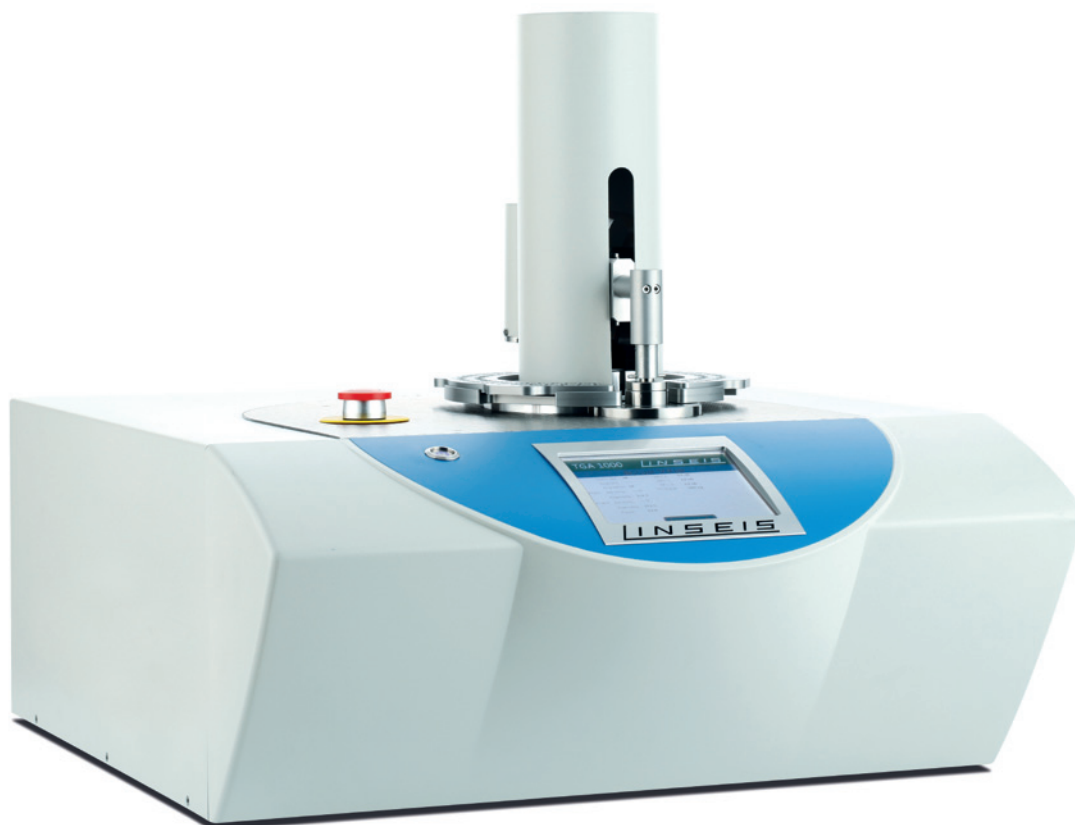

Chip-DSC 100

The DSC Principle

The Differential Scanning Calorimetry (DSC) is the most popular thermal analysis technique to measure endothermic and exothermic transitions as a function of temperature.

The instrument is used to characterize polymers, pharmaceuticals, foods/biologicals, organic and inorganic chemicals. Transitions measured include T_g, melting, crystallization, curing, cure kinetics, oxidation induction time and heat capacity.



Unsurpassed performance

- **Revolutionary sensor design** – combined heat flux sensor and furnace in one chip.
- **Unsurpassed sensitivity** – for detection of melts and weak transitions
- **Benchmark resolution** – precise separation of close lying events
- **Reliable automation** – up to 96 position autosampler
- **Widest temperature range** – from -180 °C to 600°C in one measurement



The LINSEIS Differential Scanning Calorimeters (DSC) operate in agreement with national and international standards such as: ASTM C 351, D 3417, D 3418, D 3895, D 4565, E 793, E 794, DIN 51004, 51007, 53765, 65467, DIN EN 728, ISO 10837, 11357, 11409.



INTEGRATED CHIP TECHNOLOGY

Reinventing Differential Scanning Calorimetry (DSC) – Integrated chip technology for your application needs

Revolutionary Sensor Concept

The novel Chip-DSC integrates all essential parts of DSC: furnace, sensor and electronics in a miniaturized arrangement. The chip-arrangement comprises the heater and temperature sensor in a chemically inert ceramic arrangement with metallic heater and temperature sensor.

This arrangement allows superior reproducibility and due to the low thermal mass outstanding temperature control and heating rates of up to 1000 K/min. The integrated sensor is easily user exchangeable and available at a low cost.

The integrated design of the chip-sensor delivers superior raw data, which enables a direct analysis without pre- or post-processing of heat flow data.

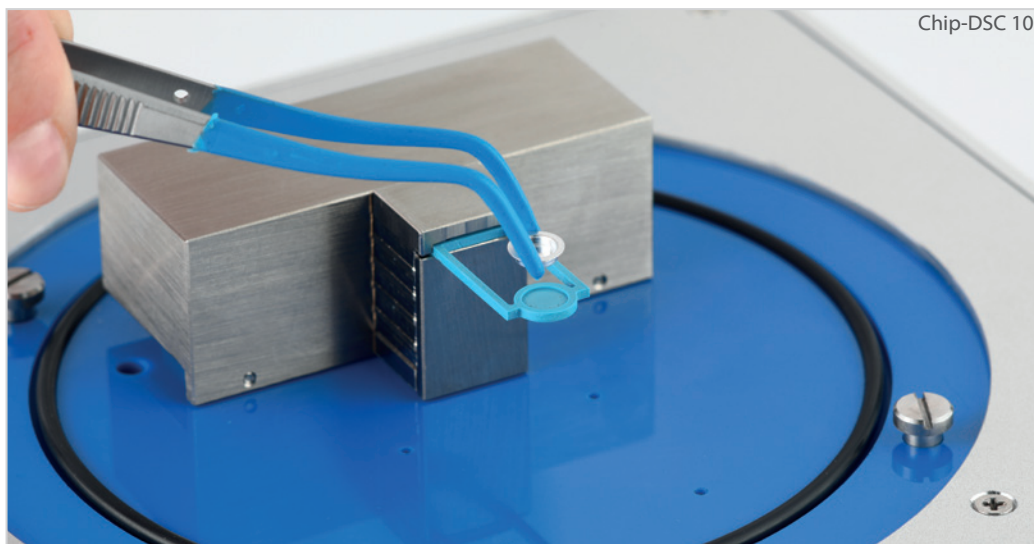
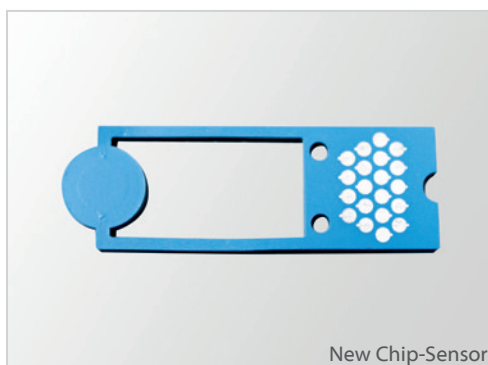

Small Footprint

The compact construction leads to a significant reduction in production cost which can be passed on to our customers. The low energy

consumption and unrivaled dynamic response results in unsurpassed performance of this revolutionary DSC-concept.

Usual DSC

New chip technology

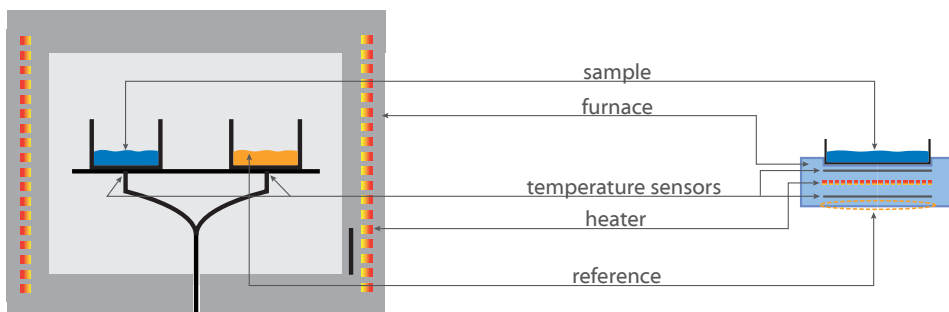

new technology allows for DSC miniaturization



COOLING OPTIONS

- Peltier-cooling system (0 – 600°C)**
This is a Peltier cooled heat exchanger. The simple to install accessory reduces the starting temperature of the DSC-sensor by 20°C in regards to room temperature. Due to the low thermal mass of the sensor the DSC can now reach linear heating from 10°C onwards. With this starting temperature 90% of polymer applications can be covered.
- LN₂-cooling system (-150 – 600°C)**
Controlled cooling system for ultra-low temperature application down to -150°C. This accessory provides the openest flexibility and cooling capacity of all available options.
- Quench-cooling-system, (-180 – 600°C)**
The quench-cooling accessory provides an open cooling container surrounding sensor and sample. Coolant dependent, e.g. dry ice or LN₂, sample temperature can go down to -180°C. This system does not allow defined gas atmospheres while measuring, as outgasing will surround the sample.
- Closed-loop intracooler (-100 – 600°C)**
Closed cycle refrigerated cooling system. Can cool down to -100°C. This intracooler eliminates the need of refilling LN₂ for cooling purposes.

Quench-Cooling-System

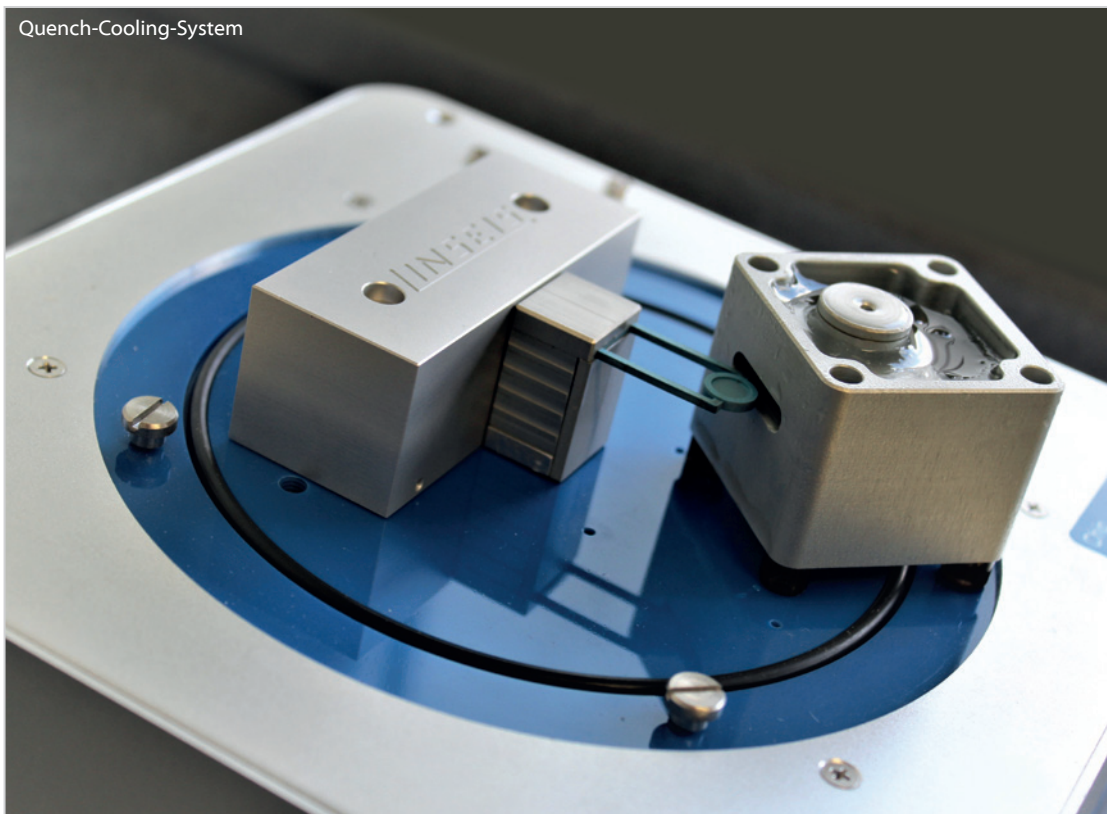

ACCESSORIES

DSC-sample-press

For optimum sample preparation of aluminum crucibles a ergonomic sample press is available.



Crucibles

Various crucibles made of aluminum, alumina, copper, gold, platinum and sapphire are available for measurements with the Chip-DSC. Other crucibles are available on request.



Sensor change

The new user exchangeable sensor can be replaced within a few seconds. This innovative concept reduces the maintenance costs drastically.

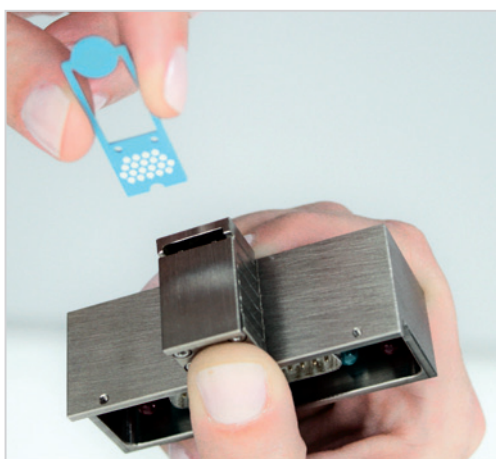

Sample robot

The Chip-DSC 100 can be equipped with a rugged and reliable sample robot. Up to 96 samples increase the efficiency significantly.

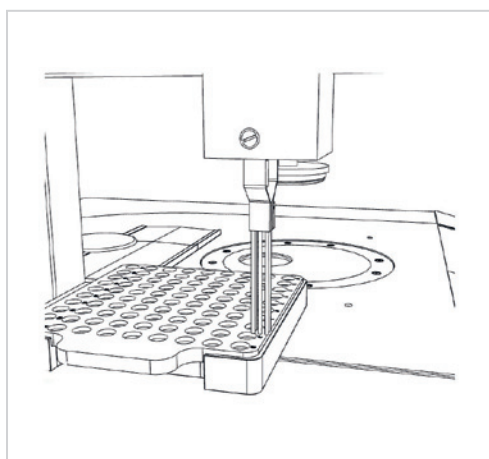

HARDWARE OPTIONS

HP DSC

The 50/150 bar high pressure cell enables OIT stability tests to monitor aging of polymers, oils and fats.

Processes under high pressures can be simulated and optimized, e.g. sorption, chemical reactions etc.

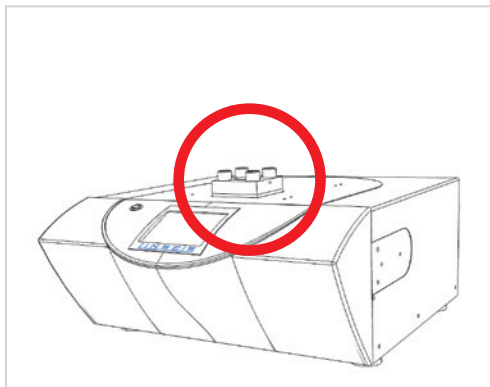

Optical DSC

The Chip-DSC 100 can be equipped with a CCD camera to observe the sample during the measurement. The visualization of the sample gives a much deeper insight to phase transitions and decomposition processes.

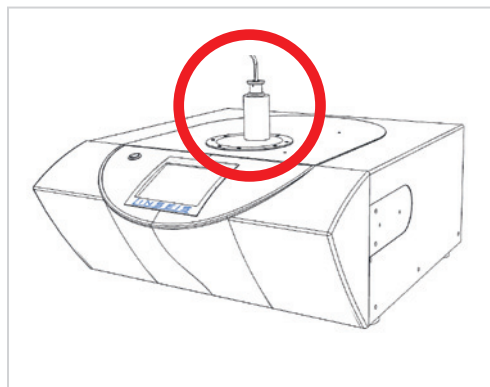
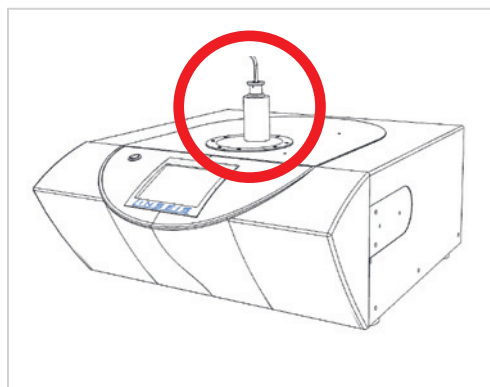

Photo DSC

The Photo cell allows measurements under UV light to investigate UV curing systems. Due to the very short time constant of the chip sensor, also fast UV curing reactions in the subsecond time scale can be measured.



RAMAN DSC

The coupling of the Chip-DSC with a Raman spectrometer can be realized very cost effectively. In the Raman spectra the amorphous and crystalline phases can be detected very precisely and *in situ*.

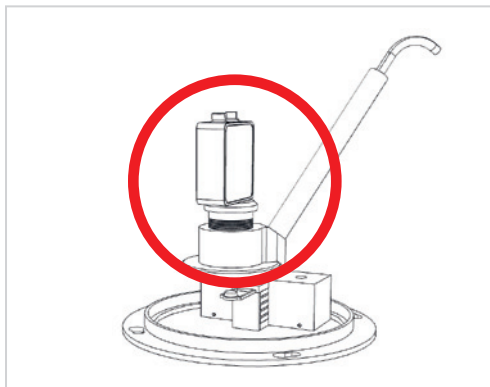

Sample Robot DSC

The sample robot for up to 96 samples increases the productivity significantly. The instrument can run automatically overnight or at the weekend. Together with the intuitive and intelligent software it reduces labour costs and saves time.

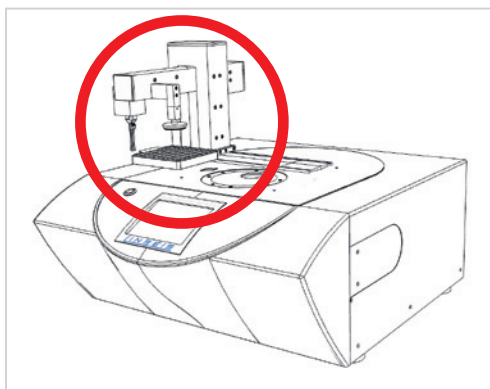

Low temperature DSC

The cooling can be realized with a variety of cooling options: intracooler, liquid nitrogen cooling or a Peltier cooling system. The available temperature range at subambient conditions can be extended down to -180°C .

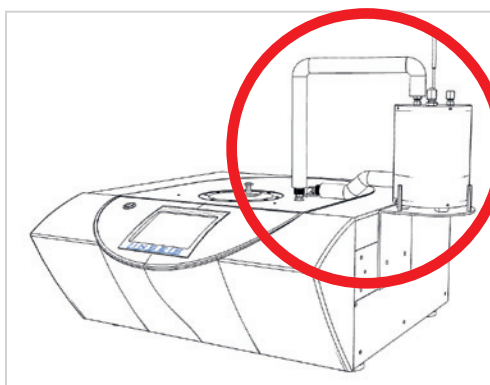

SOFTWARE

Smart Software Solutions from LINSEIS

The software greatly enhances your workflow as the intuitive data handling only requires minimum parameter input.

AutoEval offers a valuable guidance for the user when evaluating standard processes such as glass transitions or melting points. The optional thermal library product identification tool, provides a database with 600 polymers permitting an automatic identification tool for your tested polymer.

Instrument control and/or surveillance through mobile devices gives you control wherever you are.

- Software packages are compatible with latest Windows operating system
- Set up menu entries
- All specific measuring parameters (User, Lab, Sample, Company, etc.)
- Optional password and user levels
- Undo and redo function for all steps
- infinite heating, cooling or dwell time segments
- multiple language versions such as English, German, French, Spanish, Chinese, Japanese, Russian, etc. (user selectable)
- Evaluation software features a number of functions enabling a complete evaluation of all types of data
- Multiple smoothing models

- Complete evaluation history (all steps can be undone)
- Data acquisition and evaluation can be performed simultaneously
- Data can be corrected using zero and calibration correction
- Data evaluation includes: peak separation software signal correction and smoothing, first and second derivative, curve arithmetic, data peak evaluation, glass point evaluation, slope correction, zoom / individual segment display, multiple curve overlay, annotation and drawing tools, copy to clipboard function, multiple export features for graphic and data export, reference based correction



Thermal Library

The LINSEIS Thermal Library software package comes as an option for the well-known, user friendly LINSEIS evaluation software that is integrated in almost all our instruments. The

Thermal Library allows the comparison of the complete curves with a data base providing hundreds of references and standard materials within only seconds.

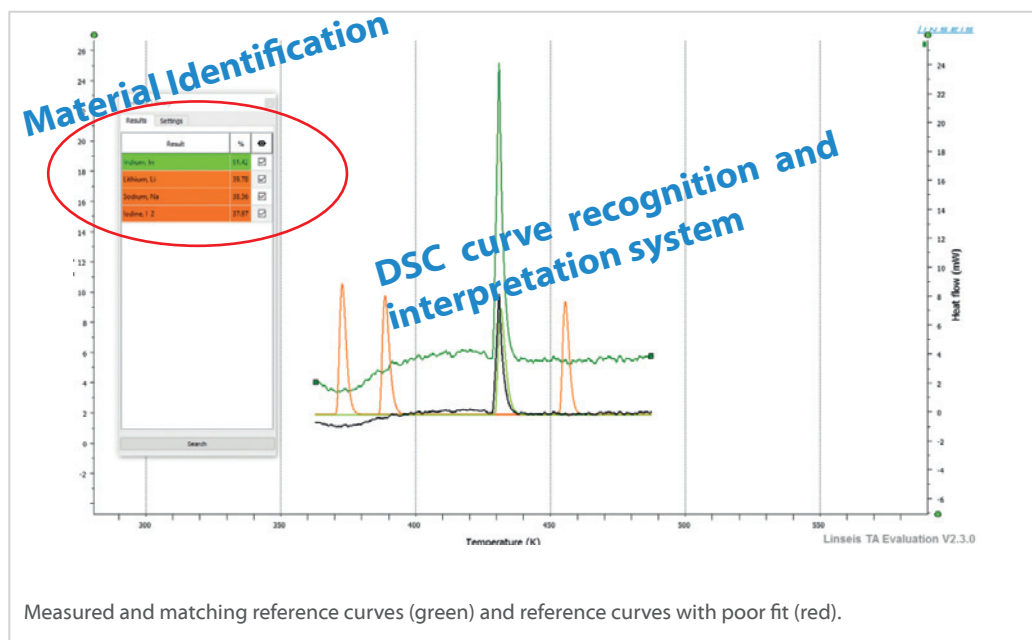

Multi-Instrument

All LINSEIS instruments DSC, DIL, STA, HFM, LFA, etc. can be controlled from one software template.

Multi-Lingual

Our software is available in many different user exchangeable languages, such as: English, Spanish, French, German, Chinese, Korean, Japanese, etc.

Multi-User

The administrator can generate different user levels providing different rights to operate the instrument. An optional Log file is available, too.

Report Generator

Convenient template selection to generate customized measurement reports.

Data Base

State of the art data base design enables easy data handling.

Kinetic software

Kinetic analysis of DSC, DTA, TGA, EGA (TG-MS, TG-FTIR) data for the study of the thermal behavior of raw materials and products.

SPECIFICATIONS

	Chip-DSC 1	Chip-DSC 10	Chip-DSC 100
Temperature range	RT up to 450 °C (no cooling option available)	RT up to 600°C -180 up to 600°C (with optional LN ₂ quench cooling)	-150°C up to +600°C (depending on optional cooling systems: Peltier, closed-loop intracooler, LN ₂)
Heating and cooling rates	0.001 up to 100 K/min	0.001 up to 300 K/min	0.001 up to 1000 K/min ballistic cooling with up to 500 K/min
Temperature accuracy	+/- 0.2K	+/- 0.2K	+/- 0.2K
Temperature precision	+/- 0.02K	+/- 0.02K	+/- 0.02K
Cool down time 400°C to 50 °C	2.7 min	2.7 min	2.7 min
Digital resolution	16.8 million points	16.8 million points	16.8 million points
Resolution	0.03 µW	0.03 µW	0.03 µW
Atmospheres	inert, oxidizing (static, dynamic)	inert, oxidizing (static, dynamic)	inert, oxidizing (static, dynamic), vacuum
Measuring range	+/-2.5 up to +/-250mW	+/-2.5 up to +/-250mW	+/-2.5 up to +/-250mW
Calibration materials	included	included	included
Calibration	recommended 6-month interval	recommended 6-month interval	recommended 6-month interval

 **Up to 80% less power consumption than standard DSC-instruments!**

APPLICATION TAWN TEST

TAWN Test – Resolution

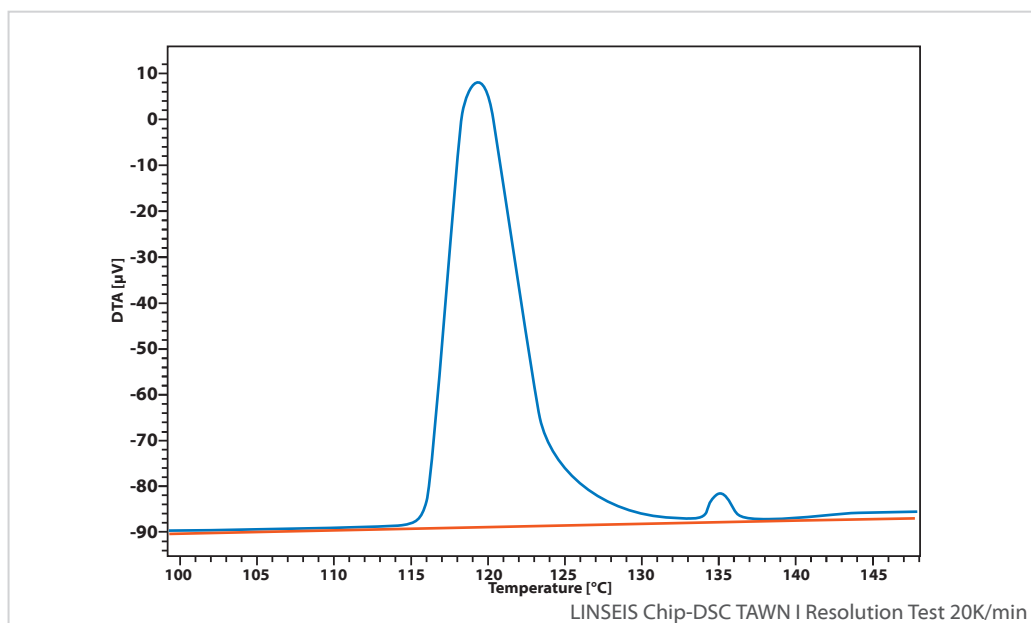

Scope

4,4'-Azoxyanisole reference material was used to perform the so called TAWN test. The substance forms a liquid crystalline phase at 120°C which transforms into a further liquid phase at 134°C with a small activation energy barrier in a second step.

This "double peak" is used in the TAWN test to investigate sensitivity and resolution of a DSC system and compare different DSC instruments with each other.

For the test an open aluminum crucible has to be used. The atmosphere must be air, argon or nitrogen, in this case we used air. The resolution is investigated with 5 mg of test substance and a heating rate of 20 K/min. The distance between the baseline to the minimum of the curve between the two peaks is measured. The ratio of this height to the height of the second peak is the resolution. The result of 0.13 is an excellent one.

APPLICATIONS

Measurement of PET granulate

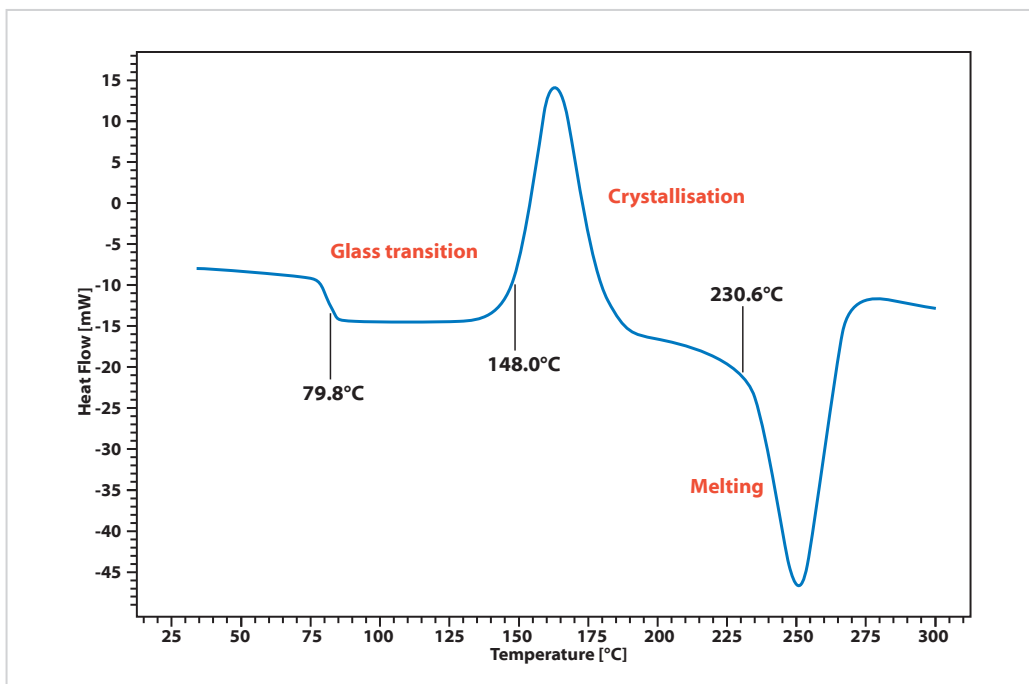

The analysis of polymers is one of the main applications of DSC. Effects like glass transitions, melting and crystallization points are of interest and often very hard to detect. The new LINSEIS Chip-DSC provides high resolution and sensitivity, making it an ideal instrument for this kind of analysis. As an example, a PET granulate was

heated, quench cooled to freeze the amorphous state and afterwards analyzed by Chip-DSC with a linear heating rate of 50 K/min. The curve shows a significant glass transition around 80°C, followed by a cold crystallization of the amorphous parts starting around 148°C and a melting peak at 230°C.

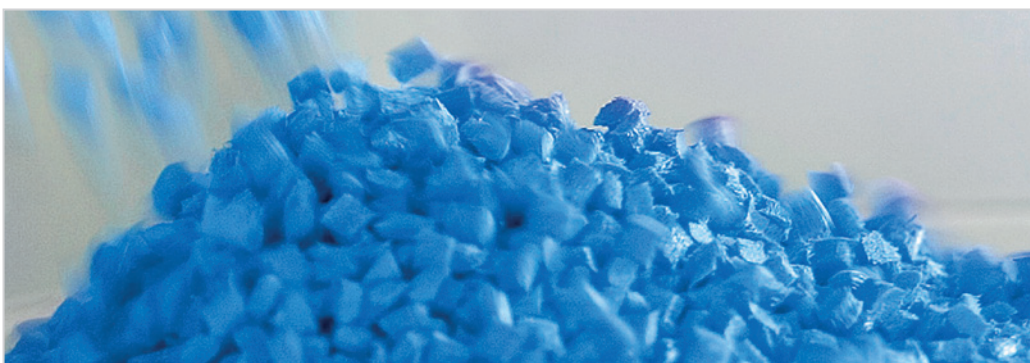

PET sample: High heating rates

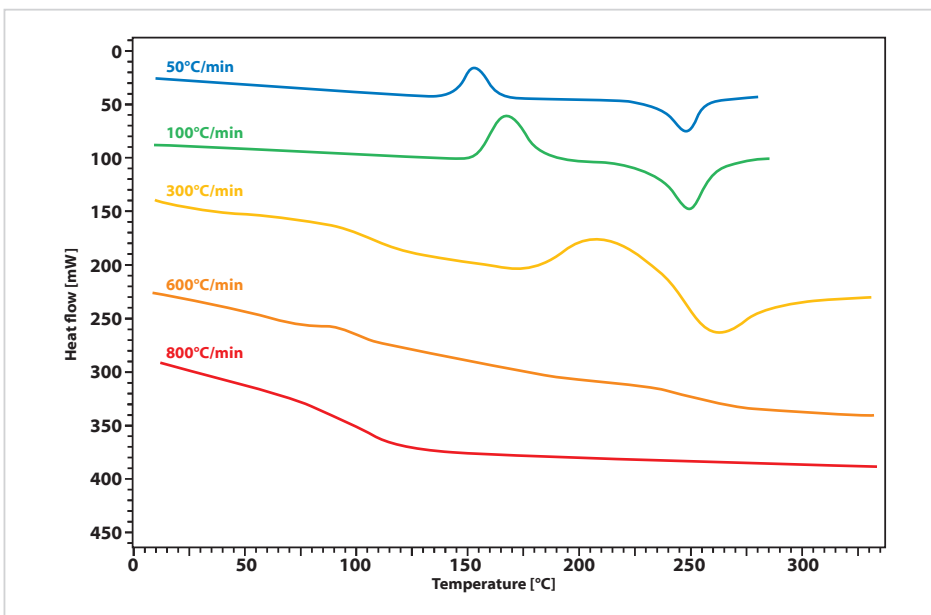

The Chip-DSC has a very low thermal mass and therefore can achieve very fast heating rates. The experiment shows a PET measurement with that was performed with heating rates of 50, 100, 300, 600 and 800K/min after an initial very fast quench cooling of the sample. The cold crystallization peak can only be observed using relatively slow heating rates. At very high heating rates, the crystallization is too slow and the corresponding peak disappears. As the sample remains in an amorphous state and as only crystalline parts can melt, no melting peak is observed anymore.

PET Cooling

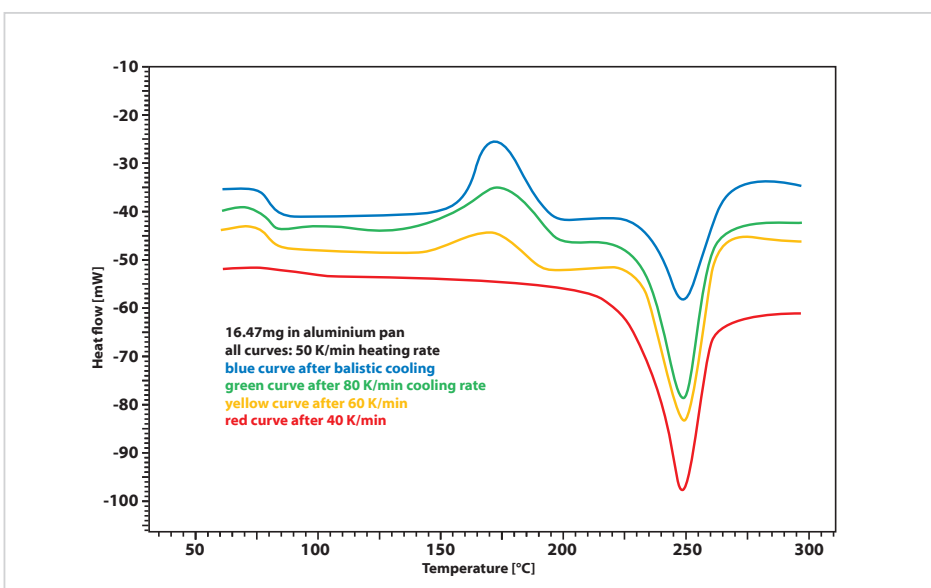

Depending on the cooling rate, the grade of crystallinity of the polymer changes significantly. During a following heating run, cold crystallization can only be observed if crystallization was not completed during a fast cooling run. If the previous cooling was slow, no glass transition or crystallization can be observed. Without the need of any active cooling such experiments with high cooling rates can be performed.

Indium sample: High heating rates

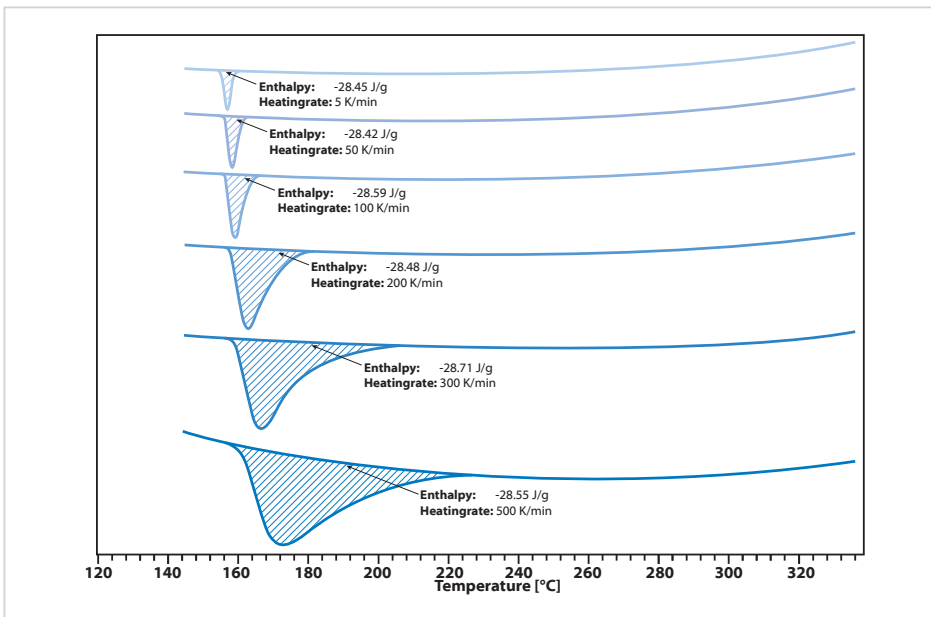

Extremely high heating rates up to 1000K/min can be achieved while the reproducibility of the melting enthalpy remains excellent.

The example shows the melting point of Indium measured with different heating rates (5 K/min; 50 K/min; 100K/min; 200K/min; 300 K/min and 500K/min).

High cooling rates without active cooling

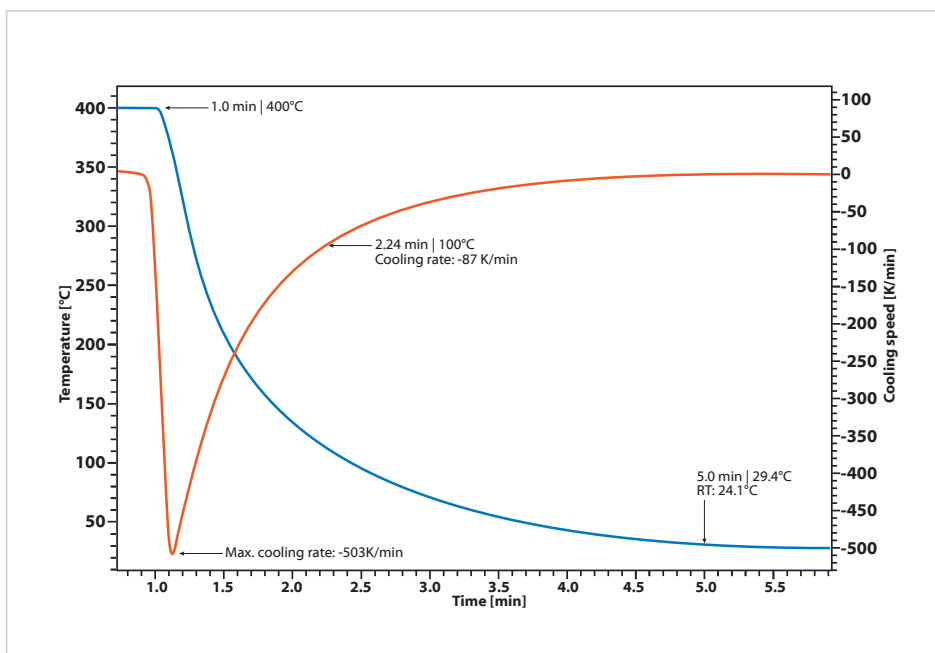

The LINSEIS Chip-DSC allows fastest possible ballistic cooling rates without any active cooler needed. Due to the low thermal mass and innovative sensor design, cooling rates up to 500 K/min from 400°C on can be reached. Even cooling to 100°C can be done with cooling rates of up to 90 K/min. A cooling from 400°C down to 30°C can be done in 4 minutes just by ballistic cooling without need of any additional cooling devices.

Of course, the signal can still be evaluated during that cooling segment and does not lose sensitivity or accuracy.

This means that a complete analysis including heating and cooling can be done in only 10 minutes without any need for optional cooling devices.

OIT- Oxidation induction time

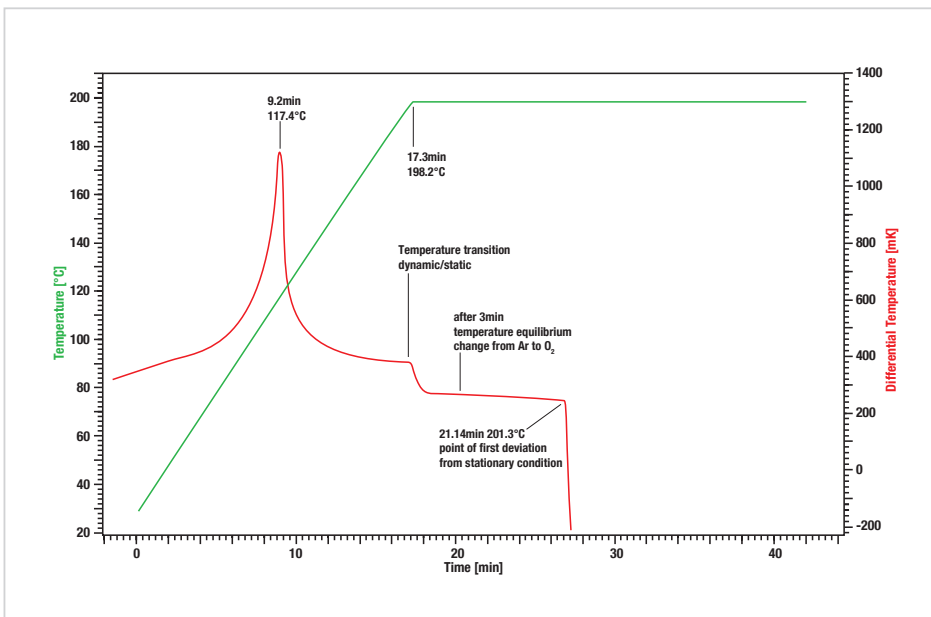

The oxidation and aging behavior can be checked using the OIT test.

A small piece of LDPE was heated with 10K/min at constant argon flow rate of 10 l/h. At 200°C, an isothermal segment was applied and later the gas flow was switched from argon to oxygen at 10 l/h.

At the point where the heating ramp goes into the isothermal segment, there is a response « step » in the heatflow signal.

After the signal has become stable again, the atmosphere was changed to oxygen. Seven minutes after that, the heat flow shows a significant change, which symbolizes the onset of the oxidation.

Cp determination

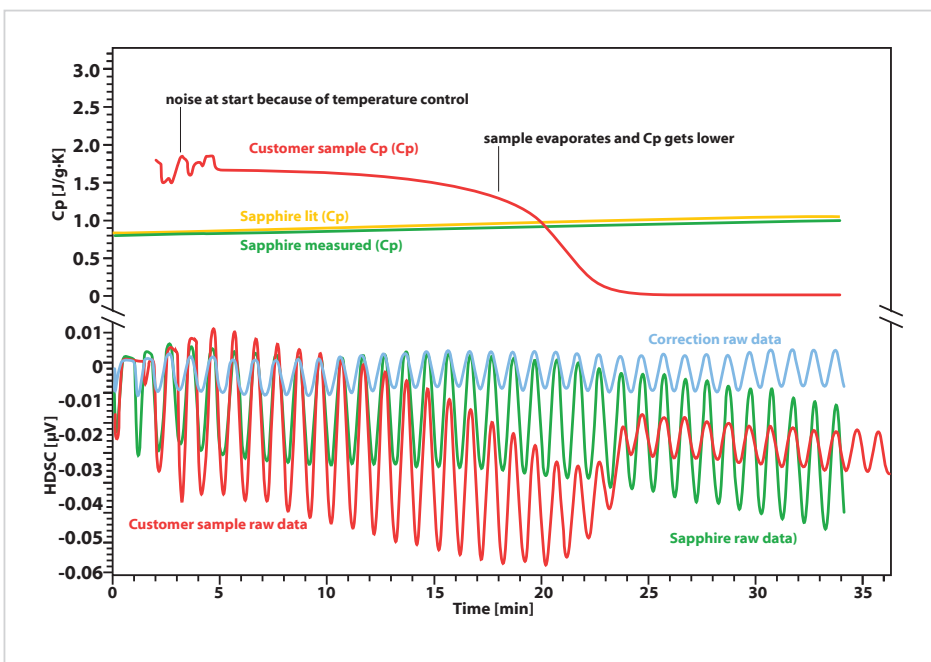

Beside the caloric measurements of phase transitions and reactions, the Chip-DSC is also able to determine the specific heat capacity. The Chip-DSC can realize this with only one crucible by using a definite temperature-modulated heating rate. Therefore a calibration measurement with a reference material (like sapphire) is recorded, followed by the measurement of the unknown sample that can be evaluated using this calibration.

The measurement shows the modulated measurement of heat capacity of sapphire at a heating rate of 10 K/min with amplitude of 3 K. Cp was determined with an error of 2%, representing an outstanding performance.

Thermochromism

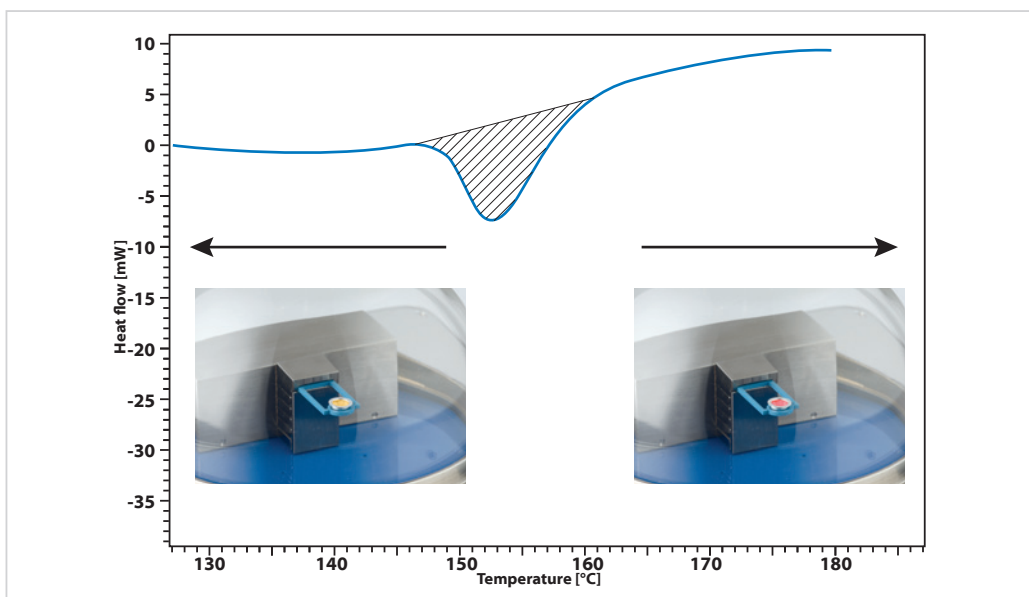

In classical DSC instruments the sample cannot be observed during the measurement. Observation can give further useful information (forming of bubbles, fumes, change of color, etc.). The graphic above shows an example of a thermochromic material, showing an endothermic

phase transition between 150 and 160°C. The phases have different colors and the color change from red to yellow can be seen through the transparent cover. A camera option for recording images is available.

Gradient of a sample during a measurement

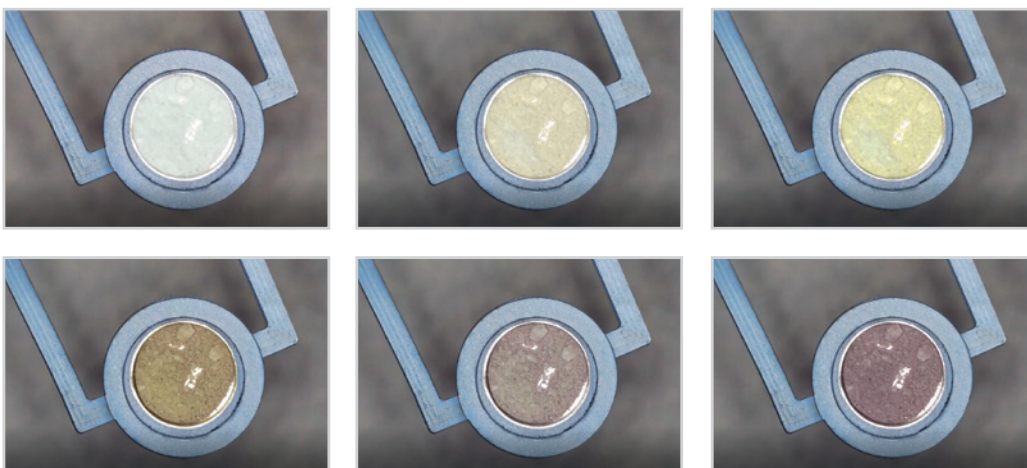

Highly energetic materials

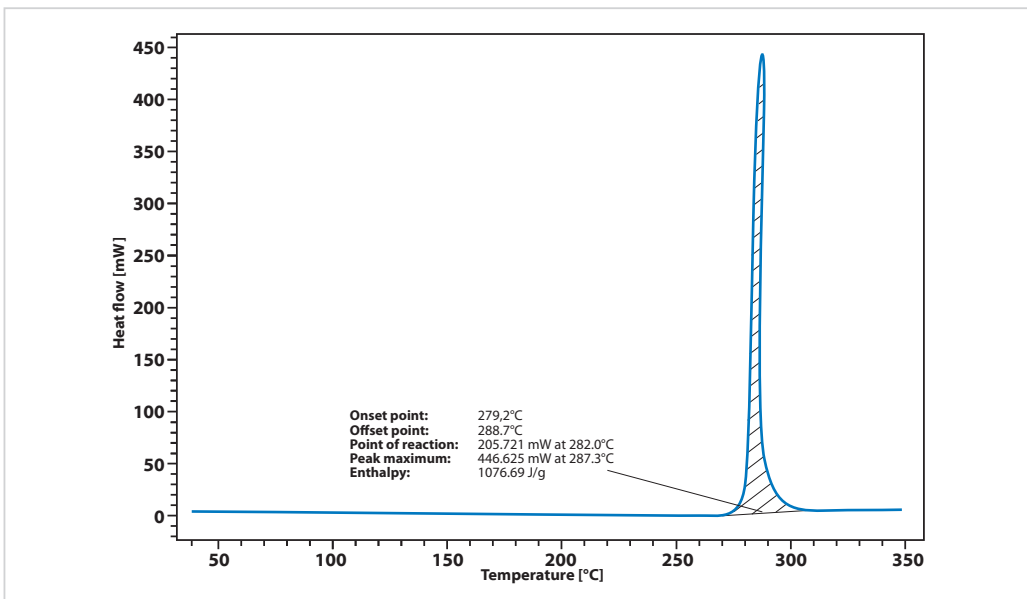

Highly energetic materials are used in airbags, as propellants, blasting materials etc.

For any type of DSC instrument, there is a risk of damaging the sensor and even the furnace. In the Chip-DSC, the chip (integrating sensor and furnace) can be easily replaced by the operator at low cost and in a short time. In case of

a damage to the instrument, the downtime of the instrument is reduced drastically. Change of the sensor needs only some seconds and the calibration can be done in approx. 15 minutes.

The example shows the DSC diagram of 2,8 mg of airbag igniter.



UV curing of polymers

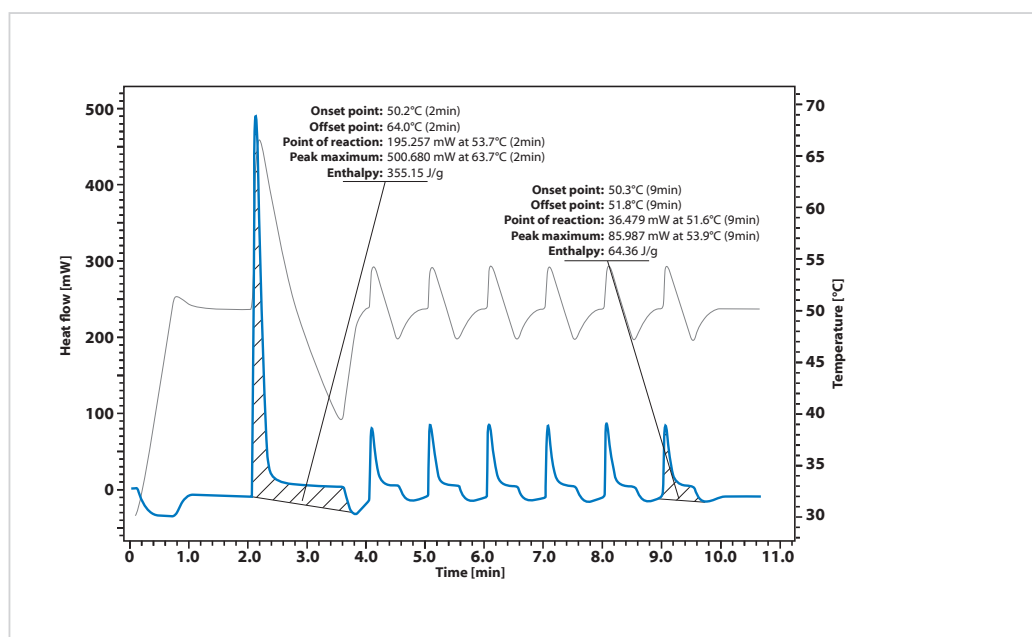

The Linseis Chip DSC in combination with an UV/LED source is a powerful tool for the characterization of fast photocurable resin systems [L. Gonzales, University of Bayreuth].

In this specific case, a mixture of a photocurable acrylate and thermally curable epoxy was used and around 10 mg of material was placed in an open crucible and irradiated with several UV light pulses until no change in peak area was detected.

The difference between the first irradiation peak and the last one, (when the area under the peak reaches a plateau, thus it is assumed that no reaction is taking place), is calculated to determine the heat of reaction for the UV-curing part, and to derive a conversion curve.

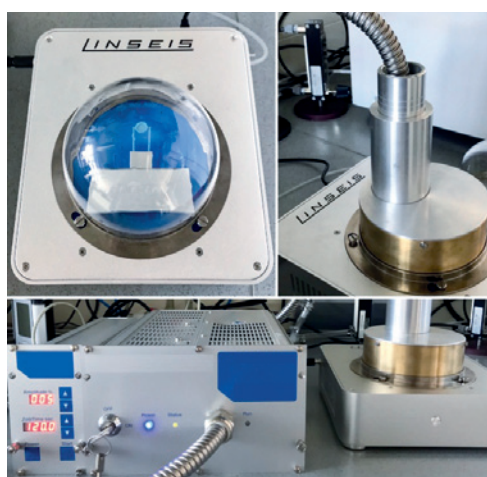

Thermal analysis of chocolate

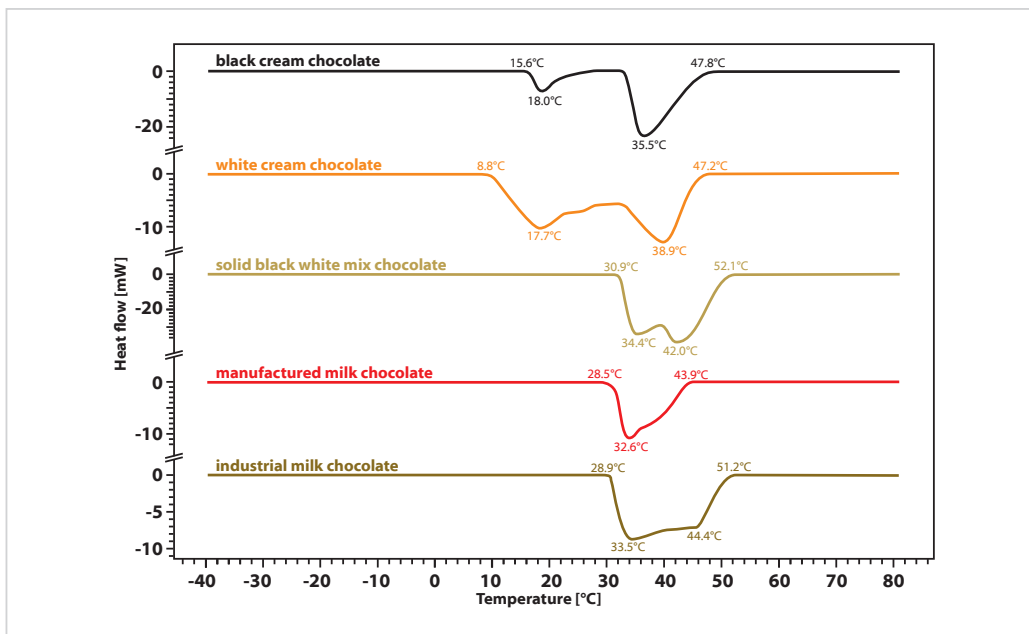

A very interesting application for DSC is the analysis of chocolate. It helps to investigate the melting behavior, melting temperature and fat content of different mixtures and therefore it is crucial for the design of a tasty, creamy product. The figure shows DSC profiles of five different chocolate samples. Each sample was precooled with liquid nitrogen to -40°C and then measured using the same conditions and similar sample mass.

The result shows that nearly all tested chocolates show a double peak that is caused by low melting milk fats and higher melting vegetable plant fats.

The quality of emulsifiers and melting temperature can be compared and used for QC and product design. In this example, the handmade chocolate shows a much more homogeneous melting behavior than cheaper industrial chocolate.



**LINSEIS GmbH Germany**

Vielitzerstr. 43

95100 Selb

Tel.: (+49) 9287 880 0

E-mail: info@linseis.de

**LINSEIS Inc. USA**

109 North Gold Drive

Robbinsville, NJ 08691

Tel.: (+1) 609 223 2070

E-mail: info@linseis.de

**LINSEIS China**

Kaige Scientific Park 2653 Hunan Road

201315 Shanghai

Tel.: (+86) 21 5055 0642

Tel.: (+86) 10 6223 7812

E-mail: info@linseis.de

**LINSEIS France**

1 Route de Trévoux

69250 Neuville/Saone

Tel.: (+33) 6.24.72.33.31

E-mail: contact@ribori-instrumentation.com

**LINSEIS Poland**

ul. Dabrowskiego 1

05-800 Pruszków

Tel.: (+48) 692 773 795

E-mail: info@linseis.de

www.linseis.com**Products:** DIL, TG, STA, DSC, HDSC, DTA, TMA, MS/FTIR, In-Situ EGA, Laser Flash, Seebeck Effect, Thin Film Analyzer, Hall-Effect**Services:** Service Lab, Calibration Service

10/19

LINSEIS